

In-Vehicle Data Acquisition System for Diagnostics of Armoured Fighting Vehicle

A. P. Deepika¹, Dr. V. Saravanan²

¹Master of Engineering, Department of Embedded System Technologies, SRR Engineering College, Chennai, Tamil Nadu

²Associate Professor, Department of Electronics and Communication Engineering, SRR Engineering College, Chennai, Tamil Nadu

ABSTRACT

In-vehicle data acquisition system for diagnostics of an AFV aims to implement a vehicular data acquisition and diagnostic system for AFV (Armored Fighting Vehicle) engine management. The purpose of this work is to build a system to acquire, analyze, and present measurement data from different types of sensors in an AFV engine, all integrated into one measurement system. As important parameters of the engine are captured during the trials and analyzed simultaneously, it serves as a useful tool for the diagnostics of the vehicle engine. This paper gives a brief description about how various sensors are used to measure engine speed, oil pressure and coolant temperature in an AFV engine and is interfaced with data acquisition system. The data acquisition system consists of signal conditioning and digitizing circuit, microcontroller and flash memory for storage of data. All parameters are collected through the data acquisition system are stored in the memory unit. The data collected are used for displaying, analyzing for diagnostics in both online and offline modes through LabVIEW software.

Keywords: AFV engine, Data acquisition, LabVIEW software, parameters, sensors.

INTRODUCTION

An Armored fighting vehicle (AFV) is a combat vehicle, protected by strong armor and generally armed with weapons, which combines operational mobility, tactical offensive, and defensive capabilities. The tank is the principal fighting armored vehicle and AFVs can be wheeled or tracked. Armored fighting vehicles are classified according to their intended role on the battlefield and characteristics. This classification is not absolute; at different times different countries will classify the same vehicle in different roles.

Technologies in AFV Firepower

AFVs are usually equipped with weapon stations for self-protection and the engagement of targets. Depending on the threat, some are equipped with pintel (bolt on which a rudder or other part turns) mount systems for light weapons to defeat troops. Others are equipped with turreted systems with cannon class weapons to defeat other AFVs.

Survivability

Today's AFVs are expected to deal with various threats that are multidirectional. To design a vehicle that can withstand these threats will require multiple technologies to enhance its survivability.

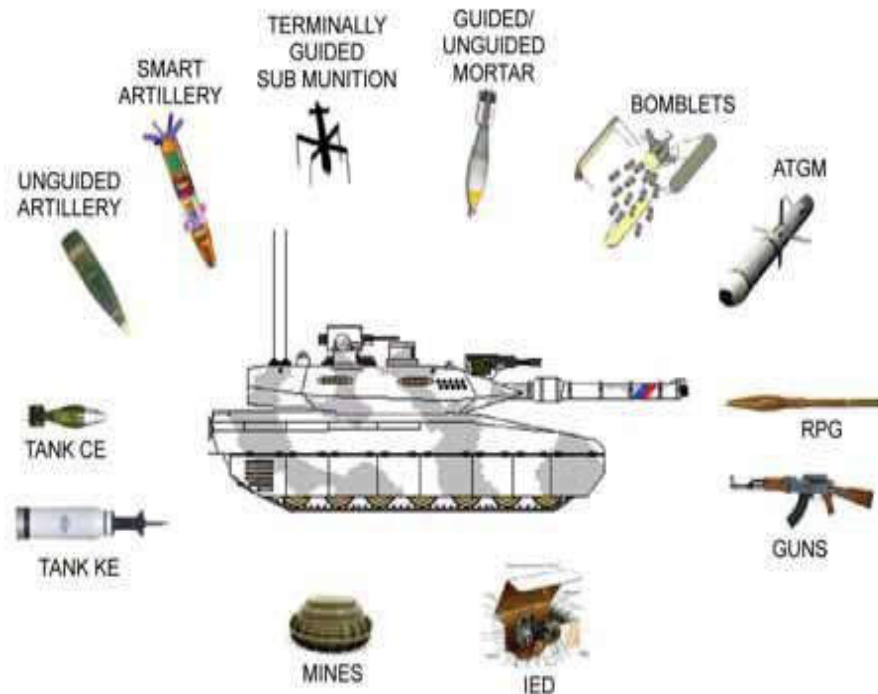

Figure 1: Typical threats AFVs face

Mobility

Mobility is the ability of the AFV to traverse from one area of operations to another. It is generally divided into strategic/operational mobility and tactical mobility. Strategic operational mobility is the capability to project the force over long distances via air, sea or land. Strategic operational mobility needs dictate the size and weight of the vehicle. Tactical mobility depends more on the performance of the platform i.e. the power train system which comprises the engine transmission and cooling system. This forms the main power source that drives the AFV. The wheels or tracks affect the AFV's maneuverability. It supports the weight of the vehicle and distributes it over the ground. The suspension system supports the vehicle, but also affects the ride comfort of the vehicle. The maximum speed at which the vehicle can travel is indirectly affected – a poor suspension design causes the driver to drive slower as higher speeds will make the ride too uncomfortable for him, even if additional power is available.

Transmission

An engine provides the power and the transmission converts this power to torque which propels the vehicle forward. A transmission will give the necessary gear ratios to transfer the power to the final drives, providing the necessary torque to overcome the road resistance. Another purpose of the transmission of a tracked vehicle is to provide steering. This is unlike wheeled vehicles which steer by the front wheels. In older transmissions, the inner track needs to be mechanically braked so that the outer track propels forward to turn the vehicle. It is an inefficient system as the power transmitted to the inner track is completely lost and converted to heat energy. Modern transmissions provide regenerative steering where the power that is usually lost in the inner track is re-directed to the outside track via a steer or zero shafts, allowing the power to be efficiently used in a steer.

Power Generation and Management

Power management is crucial to the performance of vetronics. With more computers and electronics on board, there is a greater challenge on how to generate power to sustain the operations, especially during silent watch operations. Batteries and auxiliary power units (APU) are generally used to meet these increased power requirements. However, the number of batteries used is three to four times more than a conventional AFV. Technologies such as hydrogen fuel cells and solid oxide fuel cells generate greater power with better electrical efficiency than the common APUs, and can be explored to

meet the growing power demand. However, these electrical components also generate considerable heat energy. The components have to be designed to withstand the heat.

Block Diagram

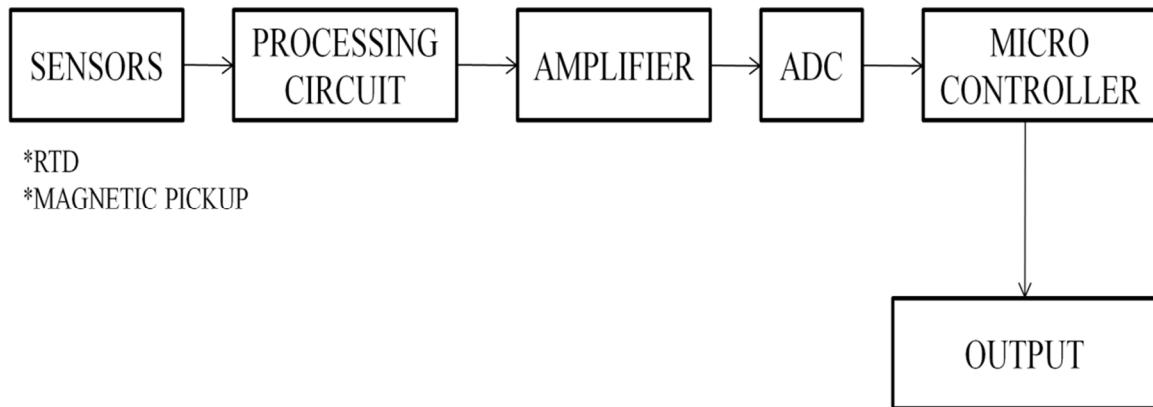

Figure 2: Block diagram of module

HARDWARE REQRIMENTS

In-Vehicle Data Acquisition System for Diagnostics of AFV Hardware

The hardware design comprises of power supply unit, temperature measurement board, pressure measurement board, speed measurement board and a PIC18F4580 microcontroller unit. All these boards are connected using DB9 connector. The outputs from all measurement boards are fed to the microcontroller unit for analysis and it serves as a useful tool for the diagnostics of the vehicle engine.

Important parameters of the engine captured during the trials are:

Table 1: parameters of engine

TEMPERATURE SENSOR (Pt1000)	PRESSURE SENSOR (Pt100)	MAGNETIC PICKUP SENSOR
Engine oil temperature	Engine oil pressure	Engine speed
Transmission oil temperature	Transmission oil pressure	Vehicle speed

Temperature Measurement:

Temperature sensor plays a vital role in AFV engine management. The temperature sensor is used to measure the temperature of the engine coolant of an internal combustion engine and transmission oil temperature.

Pt1000 as Temperature Sensor

For measuring these two parameters pt1000 sensor is used, it is an external sensor which is inbuilt in AFV engine itself. Temperature sensor contains a resistor that changes resistance value as its temperature changes. They have been used for many years to measure temperature in laboratory and industrial processes, and have developed a reputation for accuracy, repeatability, and stability. Each type of temperature sensor has a particular set of conditions for which it is best suited. The combination of resistance tolerance and temperature coefficient define the resistance vs temperature characteristics for the temperature sensor.

Signal Conditioning Circuit of Temperature Sensor:

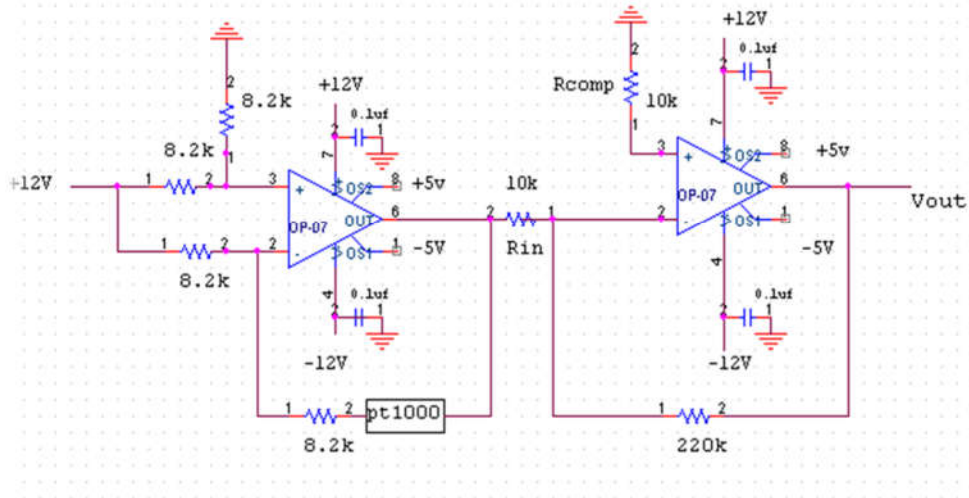

Figure 3: signal conditioning circuit of pt1000

Pressure Measurement

Pressure is one of the most important physical quantities in AFV engine management. This pressure sensor is the basis of electronic pressure measurement systems. Here, pressure sensor measures engine oil pressure and transmission oil pressure of an AFV engine.

Pt100 as Pressure Sensor

Pt100 sensor is used for measuring both engine oil pressure and transmission oil pressure. The resistance that electrical conductors exhibit to the flow of an electrical current is related to their temperature. A pt100 is a precision platinum sensor that exhibits 100Ωat 0 degree Celsius. It has a positive temperature co-efficient so as the temperature increases, so does the resistance.

Signal Conditioning Circuit of Pressure Sensor

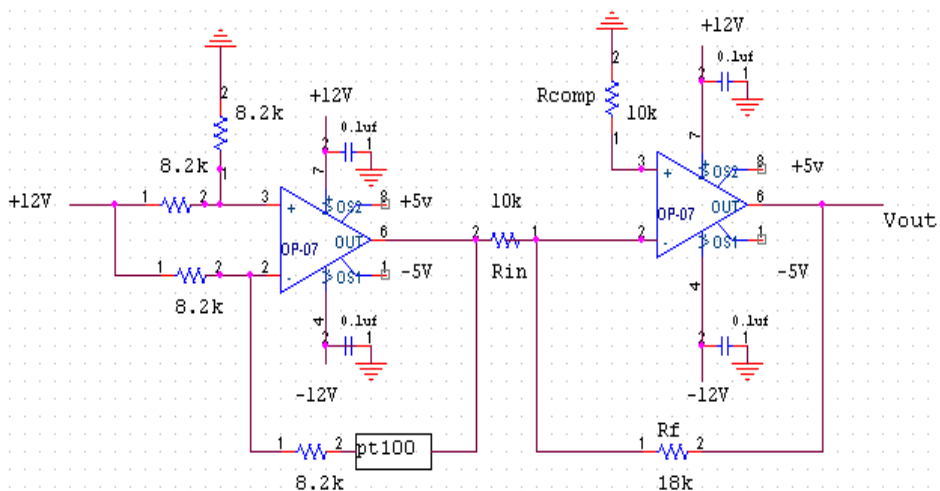

Figure 4: Signal conditioning circuit of pt100

Speed Sensor

Like pressure and temperature sensor, speed sensor also plays a vital role in AFV engine management. The speed sensor is used to measure the vehicle speed and engine speed of an AFV. The engine speed sensor becomes an important device because it provides a real value for the engine's speed. Since every AFV has its own specific speed limit, this device is put into use when checking the overall performance of the vehicle.

Magnetic Pickup as Speed Sensor

A magnetic pickup consists of a permanent magnet, a pole-piece and a sensing coil all encapsulated in a cylindrical case. An object (target) of iron, steel, or other magnetic material passing closely by its pole-piece causes distortion in the magnetic flux passing through the sensing coil and pole-piece. This in turn generates a signal voltage. The magnitude of the signal voltage depends on the relative size of the magnetic target, its speed.

The magnetic pickup signal must be converted to square waveform using appropriate electronic circuit. This square wave will be sensed by a personal computer using a suitable interface circuit. A suitable electronic circuit will convert the actual signal from the magnetic pickup to a square wave.

Signal Conditioning Circuit of Speed Sensor

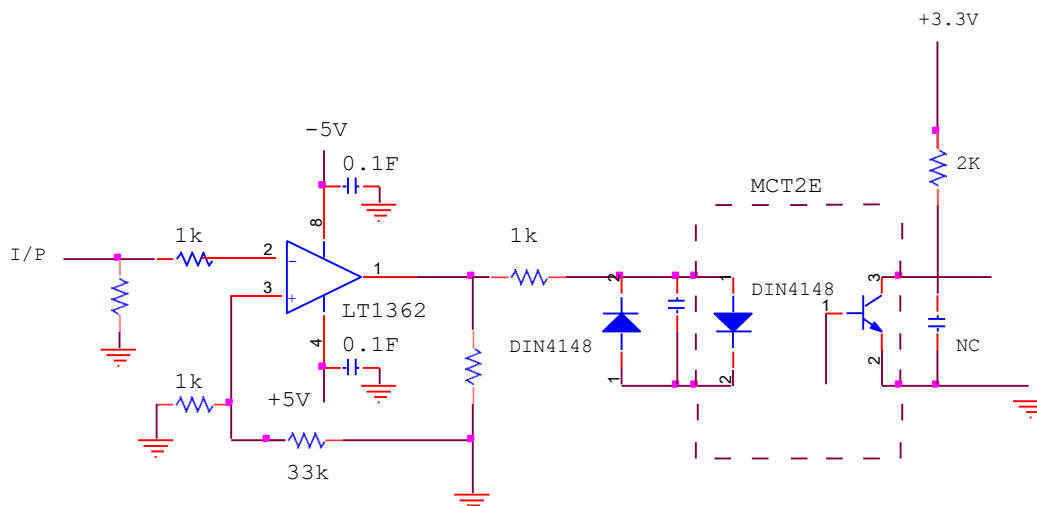

Figure 5: signal conditioning circuit of magnetic pickup

$$\text{Engine speed} = \frac{\text{frequency} \times 60}{92}$$

$$\text{Vehicle speed} = \frac{\text{frequency} \times 60}{137.22}$$

Where,

Frequency → Input (maximum upto 6.5 kHz)

Microcontroller Unit (PIC18F4580):

Outputs from all measurement board are fed to the ADC of PIC18F4580 microcontroller unit for analyzing and present measurement data.

Description

PIC18F4580 microcontroller is manufactured by microchip technology which offers high computational performance at an economical price with the addition of high-endurance, Enhanced Flash program memory. In addition to these features, the PIC18F4580 introduces design enhancements that make this microcontroller a logical choice for many high-performance power-sensitive applications. PIC18F4580 microcontroller is a 40 PDIP which operates on 40 MHz operating frequency with 32Kbytes of flash memory and can store up to 16,384 single-word instructions. Additionally to this, PIC18F4580 enclose new core features of NanoWatt technology, that can significantly reduce power consumption during operation. The

PIC18F4580 is a powerful microcontroller which provides a highly-flexible and cost-effective solution to many embedded control applications.

PIC18F4580 Development Board can be used to evaluate and demonstrate the capabilities of Microchip PIC18F4580 microcontroller. The board is designed for general purpose applications and includes a variety of hardware to exercise microcontroller peripherals. It is a fantastic tool for code debugging, development and prototyping.



Figure 6: PIC18F4580 controller

Serial Port

A serial port is a serial communication interface through which information transfers in or out one bit at a time.

DB9 Connector

The DB9 connector is mainly used for serial connections, allowing the asynchronous transmission of data provided by standard RS-232. All the sensors from AFV engine are connected to the measurement board through DB9 connector. Usually, DB9 connector is classified into two types:

- ❖ Male connector and
- ❖ Female connector

The term "DB9" refers to a common connector type, one of the D-Subminiature or D-Sub types of connectors. DB9 has the smallest "footprint" of the D-Subminiature connectors, and houses 9 pins (for the male connector) or 9 holes (for the female connector).

The "gender" of a connector is determined by its physical appearance: if pins protrude from the base of the connector, the connector is male; otherwise, if the connector has holes to accept the pins, the connector is female.

Null Modem Connection

Null modem is a communication method to directly connect two DTEs using an RS-232 serial cable. Null modem communication was possible by using a crossed-over RS-232 cable. Null modem cable is suitable for full handshaking. In this null modem cable, seven wires are present. Only the ring indicator RI and carrier detect CD signal are not linked. Null modems were commonly used for file transfer between computers, or remote operation. The cable is shown in the following figure.

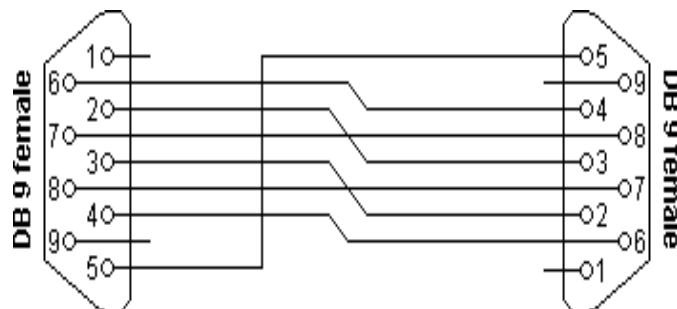

Figure 7: Null modem with full handshaking

SOFTWARE REQUIREMENT

LabVIEW Software

LabVIEW software is used for a wide variety of applications and industries. LabVIEW itself is a software development environment that contains numerous components, several of which are required for any type of test, measurement, or control application. LabVIEW contains several valuable components.

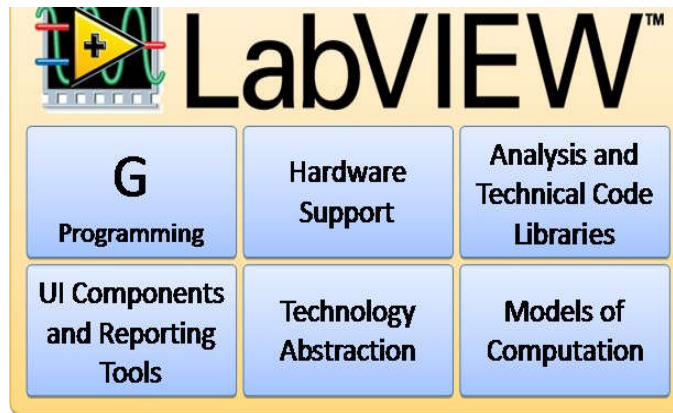

Figure 8: components of LabVIEW

Hardware Support

- Support for thousands of hardware devices, including:
 - Scientific instruments
 - Data acquisition devices
 - Sensors
 - Cameras
 - Motors and actuators
- Familiar programming model for all hardware devices
- Portable code that supports several deployment targets

LabVIEW makes the process of integrating hardware much easier by using a consistent programming approach no matter what hardware you are using. The same initialize-configure-read/write-close pattern is repeated for a wide variety of hardware devices, data is always returned in a format compatible with the analysis and reporting functions. The cross-platform nature of LabVIEW also allows you to deploy your code to many different computing platforms. In addition to the popular desktop OSs (Windows, Mac, and Linux), LabVIEW can target embedded real-time controllers, ARM microprocessors, and field-programmable gate arrays (FPGAs), so you can quickly prototype and deploy to the most appropriate hardware platform without having to learn new tool chains.

USB TO SERIAL CONVERTER

A converter from USB to an RS-232 compatible serial port; more than a physical transition, it requires a driver in the host system software and a built-in processor to emulate the functions of the serial port hardware.

- Interface: USB 2.0 Type A RS-232 (9-pin) Male.
- Install as a standard Windows COM port, full RS-232 control signals, RS-232 data signals, TxD, RxD, RTS, CTS, DSR, DTR, DCD, RI, and GND.
- Supports RS232 serial interface DB9.
- Supports over 1Mbps data transfer rate.
- Supports remote wake-up and power management.
- Supported OS: Windows 7 (32/64-bit)/Vista (32/64-bit)/XP (32/64-bit).



Figure 9: USB to serial cable

RESULTS AND CONCLUSION

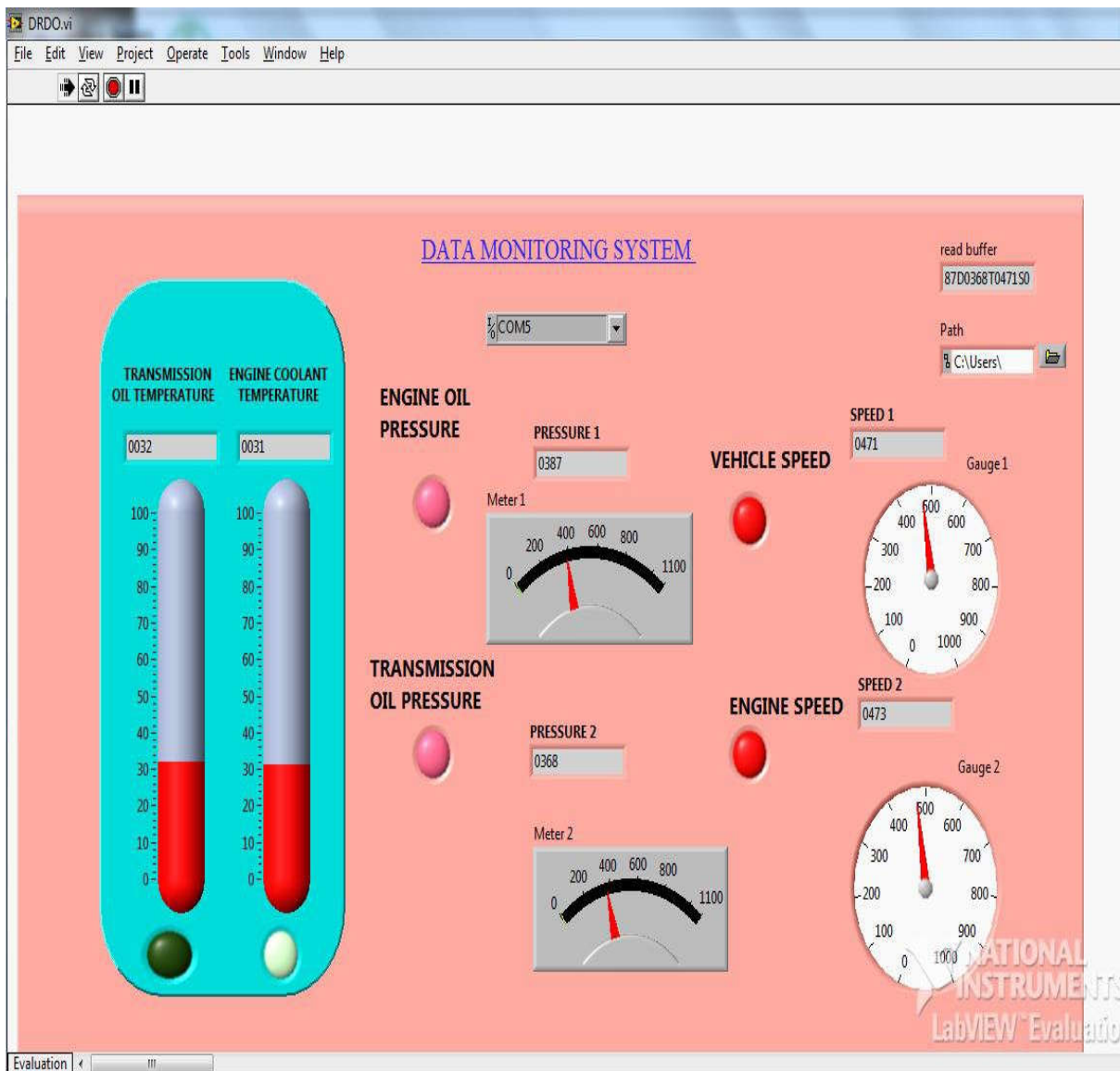
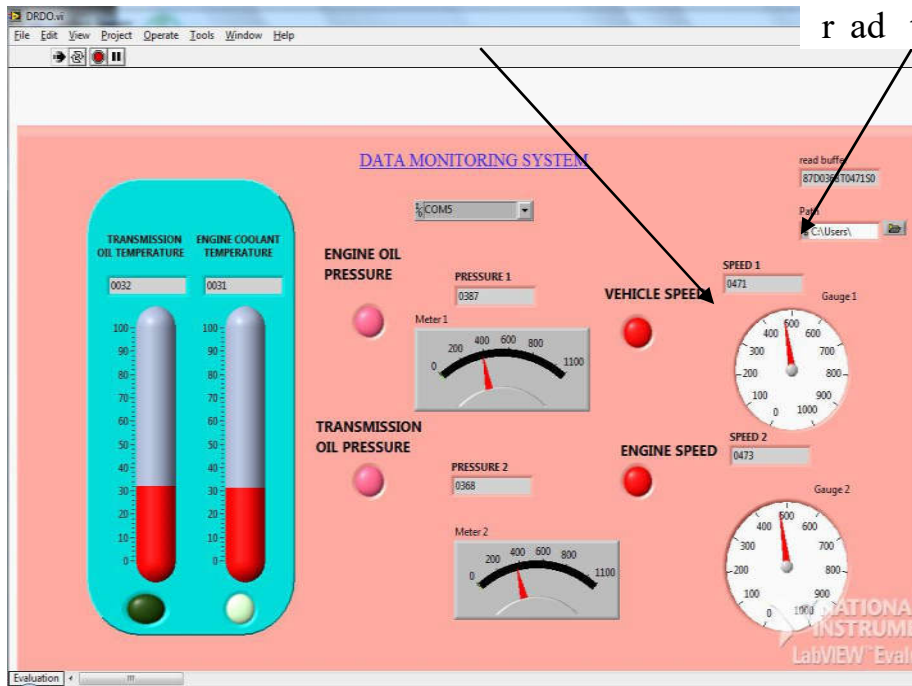

Figure 10: Final output in LabVIEW

Path for storing
data

A buffer
read the data



out - Notepad

File	Edit	Format	View	Help			
20	31	200	378	3	500		
35	35	387	364	15	44		
32	55	387	370	12	965		
38	31	347	376	50	210		
45	32	370	368	40	123		
30	32	387	374	150	554		
50	34	83	378	70	411		
32	45	386	380	44	359		
30	32	386	980	55	93		
30	41	387	347	70	41		
33	31	587	369	18	100		
34	32	37	306	20	896		
32	30	411	960	60	963		
69	32	387	473	30	563		
45	49	500	873	100	987		
32	23	356	380	500	890		
33	45	387	378	300	359		
54	66	800	173	259	459		
33	58	404	768	554	501		
32	32	370	568	900	123		
58	31	386	970	200	77		
32	31	793	277	377	507		
20	32	864	180	411	384		
34	34	345	981	383	600		
30	29	135	276	380	123		
31	32	987	369	890	20		
31	30	1000	367	387	890		
32	44	986	367	450	70		
29	67	86	372	501	890		
32	12	387	377	550	762		
32	31	300	382	750	345		
55	32	876	680	550	621		
32	32	886	176	359	812		
33	31	863	369	478	712		
30	32	963	467	243	972		
31	32	100	167	780	79		
60	30	299	373	965	82		
19	52	39	377	210	578		
32	32	304	380	674	47		
33	35	633	379	501	210		
23	32	783	375	501	270		

Figure 11: Data storage file

In an another new VI window data stored are analysed using graph tool;Path is used to select the data storage file using browse option.thus,all the parameters of AFV engine are analysed and diagnosed.

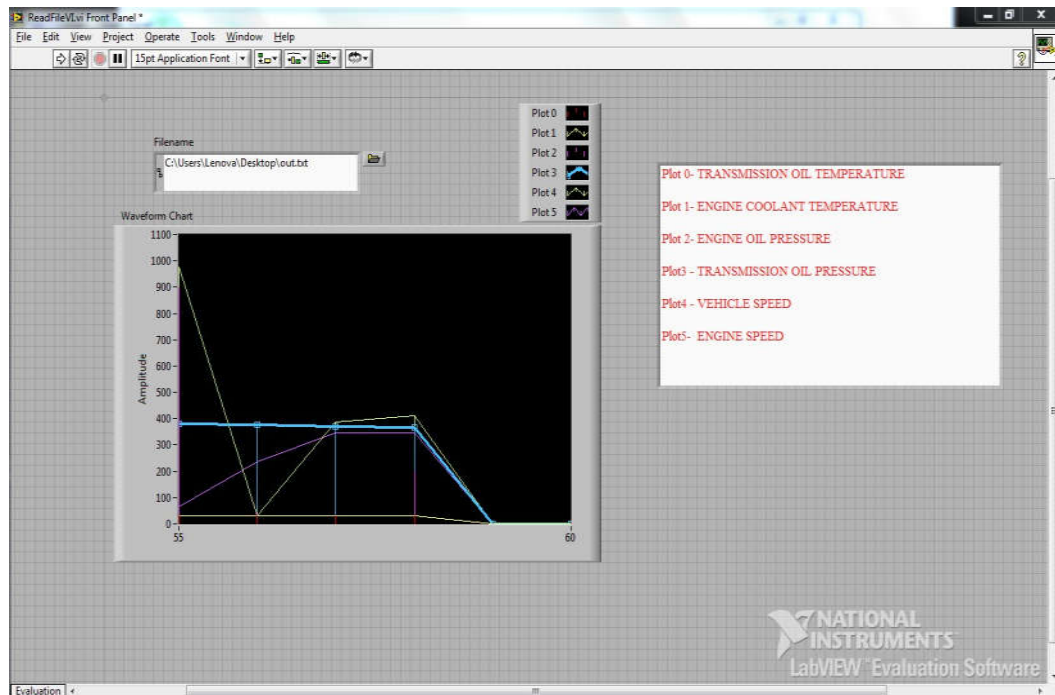

Figure 12: Graphical analysis of output

CONCLUSION

AFVs have evolved through the years. Since the beginning of World War One, AFVs have been deployed on the battlefield to achieve a tactical advantage. As technology advances, the AFV must also keep up with the changes and be ready to adapt and evolve to face these new challenges. From the above chapter discussed, came to an idea about vehicular data acquisition and diagnostic system for AFV hardware and software requirements; the final results are obtained and analysed in LabVIEW.

List of figures:

- Figure 1.1: Typical threats AFVs face
- Figure1.2: Block diagram of module
- Figure2.1: signal conditioning circuit of pt1000
- Figure2.2: signal conditioning circuit of pt100
- Figure 2.3: signal conditioning circuit of magnetic pickup
- Figure2.4:PIC18F4580 controller
- Figure2.5: Null modem with full handshaking
- Figure3.1: components of LabVIEW
- Figure3.2: USB to serial cable
- Figure4.1: Final output in LabVIEW
- Figure4.2: Data storage file
- Figure4.3: Graphical analysis of output

List of tables:

- Table2.1: parameters of engine

Abbreviations:

- AFV-Armored Fighting Vehicle
- C2-Communication to Command
- ADC-Analog to Digital Converter
- PIC-Peripheral Interface Control
- DIP-Dual in-line Package
- USB-Universal Serial Bus

REFERENCES

- [1]. Branko Livada – Radomir Janković– Nebojša Nikolić“AFV Vetronics: Displays Design Criteria” 2012 Journal of Mechanical Engineering.
- [2]. Richardson, Doug. 2001. Vetronics for Fighting Vehicles. Armada International, (1 February):20-28
- [3]. Microchip technology datasheets of PIC18F2480/2580/4480/4580
- [4]. Aljaafreh, A.; Khalel, M.; Al-Fraheed, I.; Almarahleh, K.; Al-Shwaabkeh, R.; Al-Etawi, S.; Shaqareen, W. “Vehicular data acquisition system for engine management”IEEE Conference Publications.
- [5]. Svendsen, M.; Winther-Jensen, M.; Pedersen, A.B.; Andersen, P.B.; Sorensen, T.M. “Electric vehicle data acquisition system” Electric Vehicle Conference (IEVC), 2014 IEEE International6
- [6]. Bochenek, Grace M.and Jennifer Hitchcock, 2007. Army Transitions Hybrid Electric Technology to FCS Manned Ground Vehicles. Army Magazine (October–December): 37.
- [7]. Army Justification Book, Procurement of Wheeled and Tracked Combat Vehicles (W&TCV), Department of Defense Fiscal Year (FY) 2017 President’s Budget Submission, February 2016.
- [8]. “In vehicle Data Acquisition system” byPavel Kucera, Ondrej Hyncica, Petr Honzik,,Karel Pavlata and Karel Horak appeared 2011 14th International IEEE Conference on Intelligent Transportation Systems Washington, DC, USA. October 5-7, 2011
- [9]. “Development of Engine Test Facility of Armored Fighting Vehicles” bySimon Sundara Raj, G., Rabibunnisa, H., Faizul, A., Nandagopal SAE Technical Paper 2009
- [10]. “Developing engine test software in LabVIEW” Published in AUTOTESTCON, 97. 1997 IEEE Autotestcon Proceedings 22-25 Sep 1997 with Pages 575 – 579