

# Study of Correction of Power Factor by Single Inductor Three-Level Bridgeless Boost Converter

Ajay Kumar<sup>1</sup>, Sandeep Goyal<sup>2</sup>

<sup>1</sup>Postgraduate scholar, Department of Electrical Engineering, Manav institute of Technology and Management, Hisar

<sup>2</sup>Assistant Professor, Department of Electrical Engineering, Manav institute of Technology and Management, Hisar

## ABSTRACT

In electrical engineering, the power factor of an AC electrical power system is defined as the ratio of the real power flowing to the load to the apparent power in the circuit, and is a dimensionless number in the closed interval of  $-1$  to  $1$ . In power system power factor (p.f) is an important factor of continuous quality electrical supply some time it reduces due to some reactive power disorder power factor affected and by hence the quality (voltage and efficiency) also affected. There are many methods to improve the power factor such as capacitor bank, synchronous condenser, thyristor controlled rectifier (TCR) etc. But they have losses problem so a new technique is introduced three level single inductor bridge less boost power factor correction rectifier with voltage clamp property by the MATLAB simulation technique it used bridge less three level boost topology. It consist of two different types of diode, i.e fast diode & slow diode, MOSFET, capacitor & inductor due to use of semiconductor device soft switching it has high efficiency, low device voltage stress as well as high Voltage gain. With the help of MATLAB simulation four modes of operation is processed these are (a).Charging stage in the positive half cycle and (b).discharging stage in positive half cycle (c).Charging stage in the negative half cycle and (d). Discharging stage in negative half cycle and the whole improved power factor supply is obtained in the wave form. And this output is to give the feasible input to the other electrical device such as electrical motor. It can be used in UPS for regular power supply.

## I. INTRODUCTION

Electricity is the presence and flow of electric charge. Its best-known form is the flow of electrons through conductors such as copper wires. Electricity is a form of energy that comes in positive and negative forms, that occur naturally (as in lightning), or is produced (as in generator). Electricity is the backbone of the economy and development of any country it is useful in every part of life i.e irrigation, lighting, infrastructure development and the country's security point of view. Electricity is the set of physical phenomena associated with the presence of electric charge. Although initially considered a phenomenon separate to magnetism, since the development of Maxwell's Equations both are recognized as part of a single phenomenon: electromagnetism. Various common phenomena are related to electricity, including lightning, static electricity, electric heating, electric discharges and many others. In addition, electricity is at the heart of many modern technologies. And for a quality electricity or power a suitable power factor is very essential for the supply of electricity in this report we have discussed on every point of power factor and its correction by the soft switching method over the conventional method of power factor correction. We have discussed about the single inductor three-level bridgeless boost power factor correction rectifier with nature voltage clamp. This method is based on the soft switching & switched mode power supply (SMPS).

### Correction of Power Factor by Single Inductor Three-Level Bridgeless Boost Converter having Voltage Clamp Property

This type of converter has very high output efficiency due to the soft switching technique and to give the further detail of the circuit we will have to discuss about soft switching.

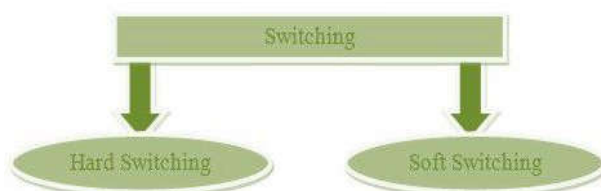

Figure 1: These are mainly two types of switching

**Hard Switching**

Hard switching are the conventional switching which is heavy, complex, costly & larger in size as well as it has some drawbacks of loss of electrical power & lower output efficiency because it consumes as well as stores some power which affects the output electrical efficiency. And these draw backs gives birth to the concept of soft switching.

**Soft Switching**

To overcome the drawbacks of hard switching, soft switching technique is introduced. In this type of switching semi-conductor power electronics switches are used. In this concept two types of switching is done.

- (a). Zero voltage switching
- (b) Zero current switching

**Zero Current Switching**

In zero current switching IGBT is used in which when current becomes at zero value then the circuit gets switched off and by this type of turn off method there is no loss in electrical power and by hence its efficiency is enhanced.

**Zero Voltage Switching**

In zero voltage switching the MOSFET is used as a power electronic switch in which switch voltage is brought to zero volt gate pulse is applied in gate terminal of switch after that smooth turn ON is achieved with eliminated switching loss.

**Three Level Single Inductor Bridgeless Boost PFC with Voltage Clamp Property**

Earlier the dual boost power factor correction rectifier is a good topology with full utilization of two MOSFET but its drawback is high conduction noise.

After that the totem pole boost bridgeless power factor rectifier is introduced with lower conduction mode (CM) noise but some drawback of reverse recovery characteristics of MOSFET don't gives it continues current mode (CCM) operation. To remove its draw back a new bridgeless power factor correction with two boost converter circuit replacing the switch leg is used to replaced the conduction of MOSFET body diode and it can also operate in continues current mode (CCM) but in this circuit a floating gate driver with extra inductor is required which makes it heavier.

After that a bidirectional boost bridge less power factor correction rectifier is introduced with bidirectional switches. But it also suffers from conduction mode (CM) noise. To replace all these demerits and drawbacks the single inductor with three-level bridgeless boost PFC rectifier is introduced. in this converter two slow diode are working as rectifier diode as well as clamping diode simultaneously. The slow diode and the intrinsic diode of MOSFET operates with switching frequency and replace the problem of reverse recovery, nature voltage clamp has achieved and voltage stress of the devices becomes half of the output voltage.

**Advantages of the Converter**

- (a). Only one inductor is required.
- (b). Low device voltage stress with the nature voltage clamp.
- (c). Voltage stress low and reduction of conduction losses and low CM noise interference.
- (d). Utilization factor of the semi conductor device becomes high.

**Operational Analysis**

To solve the problem remain in the three level bridgeless boost power factor correction with only one inductor is proposed in this given circuit. Its description is given in the figure below

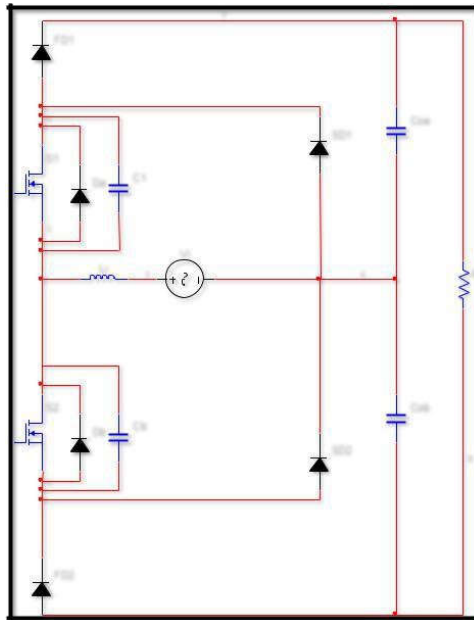
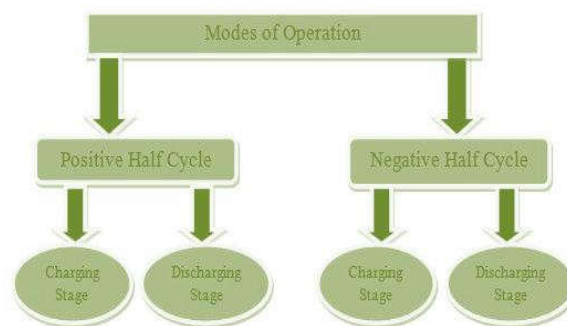

**Figure 2: Proposed converter**

The proposed topology needs only one inductor and their device utilization factor is very high. In this circuit two slow diodes ( $S_{D1}$  &  $S_{D2}$ ) can be used as rectifier diode as well as voltage clamping diode simultaneously. By this nature voltage clamping can be achieved. Two output capacitors ( $C_{0a}$  &  $C_{0b}$ ) are also connected in the circuit to clamp the line output to reduce the conduction mode noise. And by this the total output voltage becomes high due to the series output structure. And it can be used for inverter or uninterrupted power supplies. In this circuit two MOSFET are used as switch ( $S_1$  &  $S_2$ ) this two MOSFET are connected with two intrinsic diode ( $D_a$  &  $D_b$ ) and two junction capacitors ( $J_{c1}$  &  $J_{c2}$ ),  $F_{D1}$  &  $F_{D2}$  are the fast diode &  $L_i$  is the input inductors connected to the MOSFETs,  $R_0$  is the load resistance  $V_i(t)$  is the line input &  $V_{0a}$  &  $V_{0b}$  are the output voltages ( $V_{0a} = V_{0b} = V_0$ ).

The proposed converter circuit can be used as two separate boost converter circuit for each output signal during half time cycle. To make circuit simple all the devices are assumed to be ideal. The output capacitor are kept so large so that the voltage in output are remains constant.

### Modes and Stages of the Proposed Converter Circuit



**Figure 3: Modes and stages of operation**

#### Charging Stage of Positive Half Cycle

During charging stage of positive half cycle the circuit works between  $t_a$  to  $t_b$  switch  $S_2$  turns on at  $t_a$  the current is commutated from  $F_{D1}$  and  $D_a$  to  $S_2$  and  $S_{D2}$ . as  $F_{D1}$  &  $D_a$  are connected in series and reverse recovery of  $F_{D1}$  and  $D_a$  are dominated by  $F_{D1}$  (fast diode) and hence the  $F_{D1}$  blocks the whole voltage of reverse recovery and  $D_a$  is still forward biased without current. When  $S_2$  is fully on then the voltage across the  $F_{D1}$  is clamped to  $V_{0a}$  by  $D_a$ ,  $S_2$  and  $S_{D2}$ .

#### Discharging Stage of Positive Half Cycle

During discharging stage  $t_b$  to  $t_c$ , at  $t_b$   $S_2$  turns off, the current is shifted from  $S_2$  &  $S_{D2}$  to  $F_{D1}$  and  $D_a$ .

$S_2$  and  $S_{D2}$  are in series &  $S_2$  is a MOSFET there is no issue of reverse recovery theoretically for the slow diode. In next section it will be further explained as the result when the  $S_2$  is fully off,  $S_{D2}$  is still on without current & the voltage across the  $S_2$  is clamped to  $V_{0a}$  by  $S_{D2}$ ,  $D_a$  &  $F_{D1}$ .

In this stage the inductor  $L_i$  current is discharged & also decreases linearly. The capacitor  $C_{0a}$  is charged up and the capacitor  $C_{0b}$  is still delivers the power to load since  $S_{D2}$  is forward biased and  $F_{D1}$  and  $D_a$  are in the ON state, so that the voltage across  $S_{D1}$ ,  $S_2$  and  $F_{D2}$  are  $V_{0a}$ ,  $V_{0a}$ , &  $V_{0b}$  respectively.

### Charging Stage of Negative Half Cycle

During charging stage the period between  $t_d$  to  $t_e$ .  $S_1$  turn on at  $t_d$ . the current commutated from  $F_{D2}$  and  $D_b$  to  $S_1$  &  $S_{D1}$ .  $F_{D2}$  and  $D_b$  are connected in series the reverse recovery of  $F_{D2}$  and  $D_b$  are dominated by the fast diode  $F_{D2}$ . Thus  $F_{D1}$  blocks the whole reverse voltage &  $D_b$  is still forward biased without current When  $S_1$  is fully ON the voltage across  $F_{D2}$  is clamped to  $V_{0b}$  by  $D_b$ ,  $S_1$  &  $S_{D1}$ .

During this stage the inductor ( $L_i$ ) current charged by input voltage  $V_i(t)$  and increases linearly. the capacitor  $C_{0a}$  and  $C_{0b}$  delivers the power to the load in series.  $D_b$  is forward biased and  $S_1$  and  $S_{D1}$  are in ON state. So, the voltage across  $F_{D2}$ ,  $S_{D2}$  and  $F_{D1}$  are  $V_{0b}$ , 0 and  $V_{0a}$  respectively. this stage stops working when the switch  $S_1$  turns of at  $t_e$ .

These are the descriptive explanation of the charging mode in the negative half cycle in which the inductor of the power factor correction circuit based on the boost converter is working in the charging mode. And the discharging mode will be discussed just next after this charging mode.

### Discharging Mode of Negative Half Cycle

During discharging stage if negative half cycle the period is from  $t_e$  to  $t_f$ .  $S_1$  turns off. The current is shifted from  $S_1$  and  $S_{D1}$  to  $F_{D2}$  and  $D_b$ . As  $S_1$  and  $S_{D1}$  are in series &  $S_1$  is a MOSFET.

There is no reverse recovery voltage for slow diode theoretically. It will explain in the next part. as a result when  $S_1$  is fully off,  $S_{D1}$  is still ON with no current & the voltage across the  $S_1$  clamped to  $V_{0b}$  by  $S_{D1}$ ,  $D_b$  &  $F_{D2}$ . In this stage the inductor  $L_i$  current is discharged and decreases linearly. The capacitor  $C_{0b}$  is charged up and the capacitor  $C_{0a}$  still delivers power to the load.  $S_{D1}$  is forward biased and  $F_{D2}$  and  $D_b$  are in the ON state. So the voltage across  $S_{D2}$ ,  $S_1$  and  $F_{D1}$  are  $V_{0b}$ ,  $V_{0b}$ , and  $V_{0a}$  this mode ends when  $S_1$  turns ON at  $t_f$  again.

### Design Consideration

The proposed converter can be treated as continues current mode (CCM), discontinuous current mode (DCM) and current resonance mode (CRM), and the operation is similar to the traditional single switch converter.

The output capacitor is charged up throughout half cycle and discharged by the load current in the left over half cycle. so the charge current  $I_{chg}$  and the discharged current  $I_{dischd}$  through each capacitor in a line cycle are given below.

$$I_{chg} = I_0 - 2I_0 \cos(2\pi f_L t)$$

$$I_{dischd} = -I_0$$

Where  $f_L$  is the line frequency and  $I_0$  is the DC output current.

Based on the above equation the RMS current for the each capacitors are given in the next equation which is double then that in the conventional boost power factor correction converter. It is reasonable due to the series output structure.

$$I_{CRMS} = \sqrt{2} I_0$$

Based on the capacitor discharge and charge current given in the equation (1), the voltage ripple for the output capacitor  $C_0$  can be introduce as

$$\Delta V_C = I_0 \frac{1}{2\pi f_L C_0} \left( \frac{\sqrt{3}}{2} + \frac{5\pi}{6} \right)$$

Peak to peak output ripple voltage is the addition of the two capacitors (voltage ripple) which is given in the next equation it is double than that in a traditional boost PFC converter

$$V_r = 2I_0 \frac{1}{2\pi f L C_0}$$

The output capacitance can be designed based on the required voltage ripple given in equation (5) and its RMS current is given in (3).

**Simulation and Its Result**

The simulation is done in the SIMULINK, a part of the software called MATLAB.

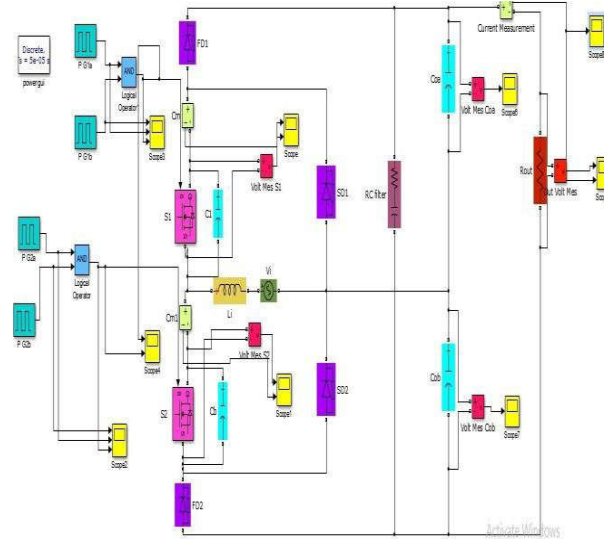

**Figure 4: Equivalent circuit of proposed topology in**

**SIMULINK**

Figure 4 is the equivalent simulated proposed topology, in which two fast diodes ( $F_{D1}$  and  $F_{D2}$ ) and two slow diodes ( $S_{D1}$  and  $S_{D2}$ ) are connected to the circuit because of their different work on different timings. The reverse recovery of the slow diode is very slow and the properties of voltage clamping makes it important in the circuit where as the fast diode has very high reverse recovery characteristics, two MOSFET is used in the circuit as the main switch naming  $S_1$  and  $S_2$ . Capacitors are used for delivering the power to the load in series. Inductor is used in the circuit for charging and discharging purposes.

All above component is simulated in the manner discussed previously and the output of the simulated circuit will obtain. All the components are of the same parameter which is discussed in the different tables of chapter no. 4 in which the detailed description of the given component is discussed.

Now we will discuss on the different parameter of the component used in the simulated circuit.

**Table 1: Components and their parameter for simulate the proposed circuit.**

| SYMBOL          | PARAMETER            | SPECIFICATION                   |
|-----------------|----------------------|---------------------------------|
| $V_i(t)$        | Line input           | 240v RMS, 796v DC, 1000w, 1.25A |
| $V_0a/V_0b$     | DC buses             | 400VDC $\pm 5\%$                |
| V               | Total output voltage | 800VDC                          |
| P               | Full output power    | 1000W                           |
| $F_{switching}$ | Switching frequency  | 100kHz                          |

|         |                  |            |
|---------|------------------|------------|
| S1,S2   | MOSFET           | SPW47N60C3 |
| FD1,FD2 | Fast diode       | IDH12SG60C |
| SD1,SD2 | Slow diode       | KBPC3510   |
| Li      | Input inductor   | 700mH      |
| C0a,C0b | Output capacitor | 2 $\mu$ F  |

### Wave Forms across the Switches

#### Input Gate Pulse Waveform of the Switch S<sub>1</sub>

The output wave form of the auxiliary switch is given below which is operating in the positive half cycle.

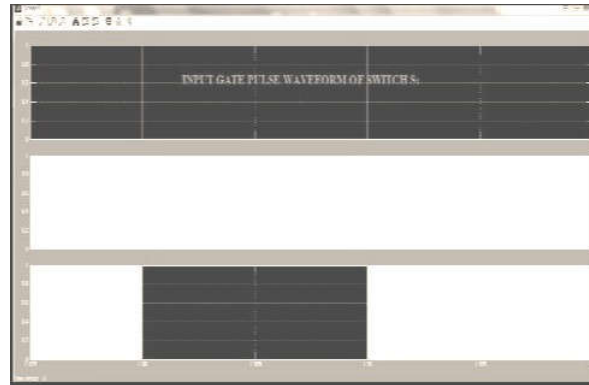

**Figure 5: The input gate pulse waveform of the switch S<sub>1</sub>.**

In case of the first auxiliary switch S<sub>1</sub>, it working in the positive half cycle and since it is connected through the AND gate hence it gives the out when both the pulse generator gives the pulse otherwise no output will obtain. Because it operates through the AND gate and the output of the AND gate will obtain in the condition only when both the input is positive or one. Now we will discuss about the output wave form of the second auxiliary switch S<sub>2</sub>.

#### Output Waveforms (Current & Voltage) Waveform Switch S<sub>1</sub>

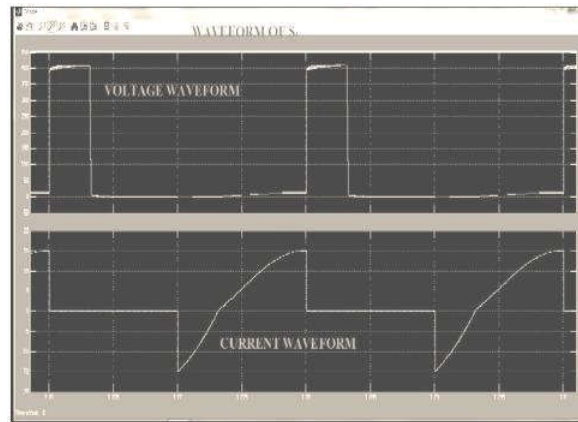
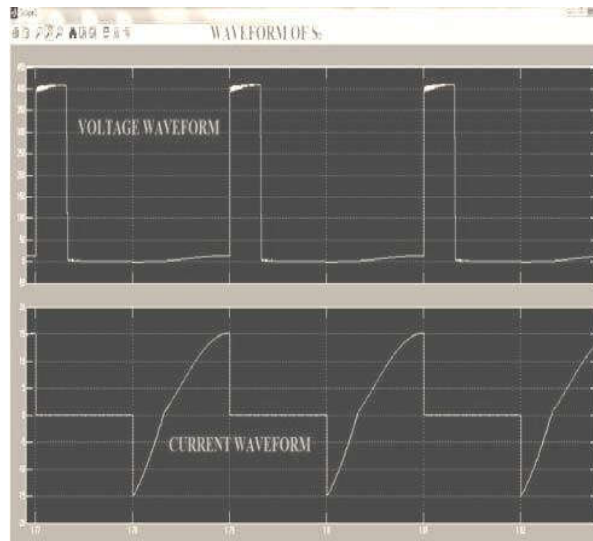

**Figure 6: Output waveform of switch S<sub>1</sub>**

In the above figure of output waveform which is obtained from the switch S<sub>1</sub> we have seen that when the current is at the minimum (i.e zero) the value of the voltage is at its maximum Value and this is the condition satisfy the zero voltage switching (ZVS) where the value of the voltage becomes maximum after when the value of the current becomes zero and after that when the current is going to be increasing the value of the voltage drops drastically and

becomes zero, at instant when the current attains its maximum value as shown in the wave form at the same instant it becomes and the voltage attains its maximum value and this condition satisfy the zero current switching (ZCS).

#### Waveform of Switch S<sub>2</sub>



**Figure 7: Output waveform of switch S<sub>2</sub>**

#### Output Load Waveform

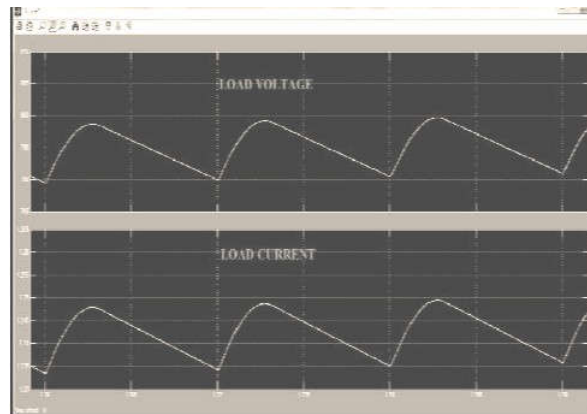

**Figure 8: Load voltage and current waveform**

The waveform of load current and load voltage is shown in this above figure we have seen that when the two voltage signal of 400V each passed through the LC filter then the combined waveform of both the input signal comes from the output capacitor is obtained of 800V and the main thing we have seen is that both the current and the voltage signal are in the same manner, i.e. unity power factor or the corrected power factor which gives ideal quality power supply which is good for the uninterrupted power supply or for the battery charging which will give the longer life. And by this we have achieved the main goal of PFC for quality power.

#### CONCLUSION

A single inductor three-level boost bridgeless power factor correction rectifier with natural voltage clamp characteristics has been proposed in this thesis work. In the proposed converter circuit two slow diodes are used as clamping diode and rectifier diode simultaneously. Though the slow diode and the intrinsic diode of the MOSFET operate with the switching frequency. So the problem of reverse recovery has been shorted out. The voltage stress of all the power electronic devices is reduced to  $\frac{1}{2}$  of the total output. With achievement of natural voltage clamping.

Its use with the UPS shows its versatility in the field of the power system. Circuit has some advantages.

- (a). It requires only one inductor.
- (b). Low voltage stress with nature voltage clamp.
- (c). Low conduction losses and low CM noise.
- (d). Utilization factor of device is high.

#### REFERENCES

- [1]. Shoyama, T. Ninomiya, T. „Mechanism of common mode noise reduction in balanced boost switching converter“. proc. IEEE Power electronics specialist conf., Aachen, germany , June 2004, pp. 1115- 1121.
- [2]. De Souza, A.F. ,Barbi, I.“High power factor rectifier with reduced conduction and commutation losses“. Proc. IEEE telecommunication energy conf., Copenhagen, Denmark, june 1999, pp. 1-5.
- [3]. Wang, C. „A novel ZCS-PWM power-factor pre regulator with reduced conduction losses“, IEEE trans. Ind. Electron. , 2005,52, (3), pp. 688-700.
- [4]. Su, b Zhang, J. ,Lu, Z. „Totem pole boost bridgeless PFC rectifier with simple zero current detection and full range ZVS operating at the boundary of DCM/CCM“, IEEE Trans. Power electron. , 2011, 26,(2), pp. 426-435.
- [5]. Ismail, E.H „Bridgeless SEPIC rectifier with unity power factor and reduction conduction losses“, IEEE trans. ind. electron., 2009, 56, (4), 1147-1157.
- [6]. Huber, L., yungtaek,J. , Jovanonic, M.M. „performance evaluation of bridgeless PFCboost rectifiers“IEEE trans power electron. , 2008, 23 , (3) , pp. 1381-1390.
- [7]. W.y.Choi, J. Kwon, E.H .Kim,J.J.Lee,B.H Kwon, „Bridgeless boost rectifier with low conduction losses and reduced diode reverse recovery problem“. IEEE trans. Ind. Electron. 54,(2), pp. 768-780, April 2007.
- [8]. Y. Jang and M.M. Jovanonic, „interleaved boost converter with intrinsic voltage doubler characteristics for universal line PFC front end“IEEE trans. Power electron. , 22 (4) pp 1395-1401, July 2007.
- [9]. Dr. P.S. Bhimbra “Power Electronics” Khanna publishers, India.
- [10]. M. H. Rashid „Power electronic circuit, devices and its application“Pearson Education Second edition.
- [11]. Data sheet of power MOSFET „SPW47N60C3“Infineon technologies.
- [12]. Data sheet of Slow diode „KBPC3510“Semtech electronics limited.
- [13]. Data sheet of fast diode „IDH12SG60C“Infineon technologies.